

TECHNICAL DATA

SINGLE DRUM ROLLERS

BW 216 DH-5, BW 216 PDH-5

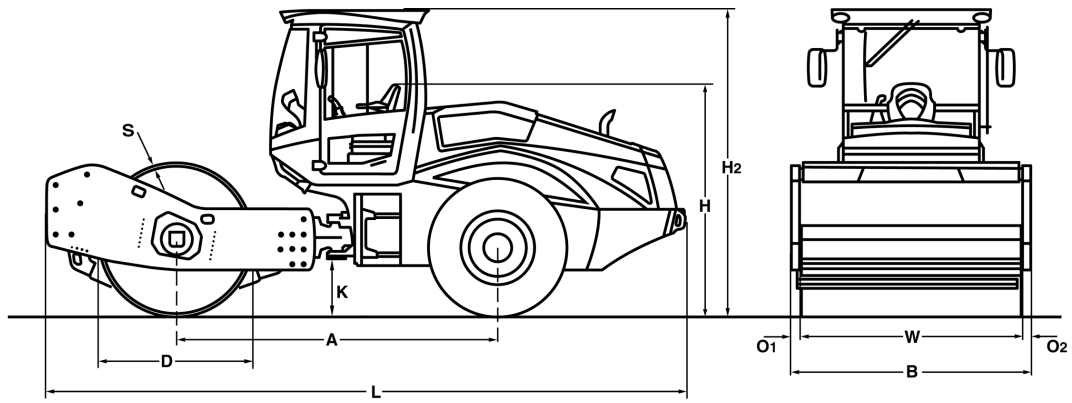



Dimensions in mm

	A	B	D	H	H2	K	L	O1	O2	S	W
BW 216 DH-5	3113	2300	1500	2250	2990	490	6220	85	85	30	2130
BW 216 PDH-5	3113	2300	1480	2250	2990	490	6220	85	85	25	2130

Shipping dimensions in m3

BW 216 DH-5
BW 216 PDH-5

without ROPS

32,189
 32,189

with ROPS

42,775
 42,775

Machine type	Compaction output (m3/h)			
	Rock fill	Gravel, sand	Mixed soil	Silt, clay
BW 216 DH-5	700-1400	480-960	360-720	210-420
BW 216 PDH-5	700-1400	480-960	360-720	250-580

Machine type	Compacted layer thickness (m)			
	Rock fill	Gravel, sand	Mixed soil	Silt, clay
BW 216 DH-5	1,10	0,75	0,55	0,30
BW 216 PDH-5	1,20	0,80	0,60	0,35

Technical Data**BOMAG
BW 216 DH-5****BOMAG
BW 216 PDH-5****Weights**

Grossweight	kg	17.910	17.950
Operating weight CECE w. ROPS-cabin	kg	16.000	17.100
Axle load, drum CECE	kg	10.800	11.900
Axle load, wheels CECE	kg	5.200	5.200
Static linear load CECE	kg/cm	50,7	

Dimensions

Working width	mm	2.130	2.130
Track radius, inner	mm	3.875	3.875

Driving Characteristics

Speed	km/h	0- 10,0	0- 10,0
Max. gradeability without/with vibr.	%	59/57	61/59

Drive

Engine manufacturer		Deutz	Deutz
Type		TCD 4.1 L4	TCD 4.1 L4
Emission stage		Stage V / TIER4f	Stage V / TIER4f
Exhaust gas aftertreatment		DOC+DPF+SCR	DOC+DPF+SCR
Cooling		Liquid	Liquid
Number of cylinders		4	4
Performance ISO 3046	kW	115,0	115,0
Performance SAE J 1995	hp	155,0	155,0
Speed	min-1	2.100	2.100
Fuel		Diesel	Diesel
Electric equipment	V	12	12
Drive system		hydrost.	hydrost.
Drum driven		standard	standard

Drums and Tyres

Number of pad feet			150
Area of one pad foot	cm2		137
Height of pad feet	mm		100
Tyre size		23.1-26 12PR	23.1-26 12PR

Brakes

Service brake		hydrost.	hydrost.
Parking brake		hydromec.	hydromec.

Steering

Steering system		oscil.artic.	oscil.artic.
Steering method		hydrost.	hydrost.
Steering / oscillating angle +/-	grad	35/12	35/12

Exciter system

Drive system		hydrost.	hydrost.
Frequency	Hz	30/36	30/36
Amplitude	mm	2,10/1,10	1,70/0,90
Centrifugal force	kN	285/220	285/217
Centrifugal force	t	29,1/22,4	29,1/22,1

Capacities

Fuel	l	250,0	250,0
------------	---	-------	-------

Technical modifications reserved. Machines may be shown with options.

Standard Equipment

- BOMAG ECOMODE
- Double pump system for travel drive
- Self locking differential
- Rear axle with twin spring accumulator brakes
- Hydrostatic travel and vibration drive
- Hydrostatic articulated steering
- Articulated joint lock
- Seat with arm rest and adj. for position and height
- Battery disconnect switch
- Single lever control for travel and vibration
- Warning, information and operation displays with LCD
- Loading mode
- Emergency STOP
- Working lights front / rear
- Back-up alarm
- 2 Scrapers
- Warning horn
- Tractor tires (PDH)

Optional Equipment

- * ROPS/FOPS cabin with seat belts
 - Sliding window
- ROPS/FOPS with safety belt
- Rearview camera
- Air condition
- Radio (Bluetooth)
- Pre start cabin heating
- Comfort package: Adjustable seat and adjustable steering column
- Rotary beacon
- Indicator and hazard lights
- BOMAG ECOSTOP
- ECONOMIZER
- TERRAMETER
- BOMAG TELEMATIC POWER
- Special painting
- Padfoot segment kit (DH)
- Environmentally compliant hydraulic oil
- Measuring- and machine data interface for third-party suppliers
- Reversing alarm buzzer with broad band audio
- LED Working lights (Cabin)
- Reversing alarm buzzer with broad band audio

* Standard delivery with CE conformity
(valid within European Union)#72

